

# VPS-30 Vehicle Pay Station

With TIBA's **Vehicle Pay Station**, patrons can scan or pay before exiting in a simple and seamless automated parking experience. The VPS-30 has options for an EMV-compatible chip terminal, contactless card reader and magnetic card reader for easy credit card payment. Additionally, the device accepts and dispenses bills and prints receipts. Maximize revenue with the option to pay in lane and collect fees around the clock.

As with all TIBA equipment, maintaining VPS-30 is simple and straightforward. Cash sits in a separate housing, so staff can perform routine maintenance while only the manager has access to cash.

## Features\*

- Motorized Barcode reader to scan and process tickets
- 2 or 3 denomination bill dispenser
- EMV compatible with dual interface for chip and magnetic stripe cards for credit card payment
- Receipt printer
- Proximity reader for monthly parkers
- TFT Color hi-res display
- Loop detector
- Analog, Digital or VOIP Intercom
- Stainless steel housing
- Data line surge protection and heater

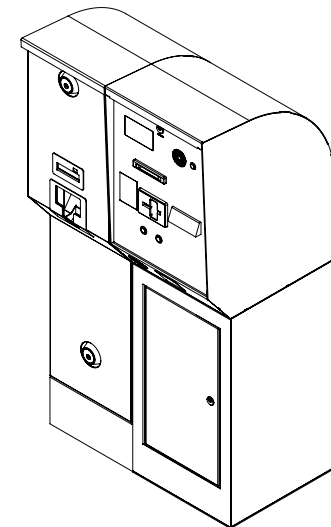

\* Not all features are available or standard in all regions.  
Check with your local sales person for availability.

# VPS-30 Vehicle Pay Station

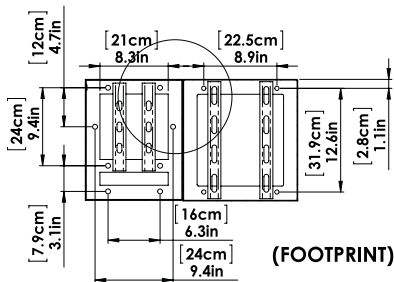
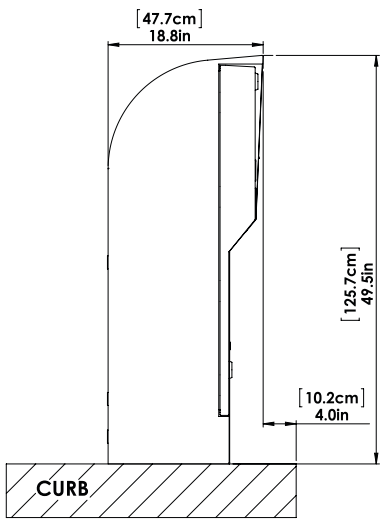
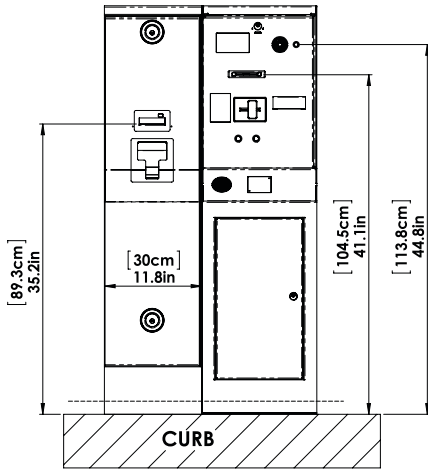

## Features

Ticket Verifier	Motorized barcode scanner
Monthlies/Employees	Access via proximity card, magnetic stripe cards, AVI, or key pad
Credit Card Reader	Supported
Receipt Printer	Supported
Bill Acceptor	Bills are read all four ways
Bill Dispenser	Returns change in two or three different banknotes
Heater	Supported
Loop Detector	Supported
Customer Display	TFT color hi-res display
Intercom Substation	Analog, digital or VOIP intercom
Surge Protection	Built in data-line surge protector
Hotel or Congress Ticket	Optional

## Operation

Processor	Embedded industrial controller
Communication & Network	RS-485 industrial communication or TCP/IP ethernet communication
Clock	Built in; backed up by lithium ion battery; keeps clock and data for up to 10 years
Off-Line Operation	Full off-line operation capability
Monitoring	Transaction and all events monitored on TMS software in real time

## Housing – Stainless Steel

Measurements	25.6" (65 cm) width; 18.7" (47.4 cm) depth; 49.6" (126.1 cm) height
Weight	230 lbs. (104 kg)
Color (Housing)	Standard: White RAL 9010 Optional: Custom colors available
Locks	Individual locks for cash unit, verifier unit and ticket retrieval door.

## Electrical

Voltage	100-240V AC 50-60 HZ
Current	12.5A max. with heater
Power Consumption	1486W with heater
Operating Voltage	12V, 24V DC

## Environment Conditions

Operating Temperature	-20° to 50°C (-4° to 122° F) with heater
-----------------------	--

## Regulatory



Safety	<ul style="list-style-type: none"> <li>• UL 60950-1:2007</li> <li>• CAN/CSA-C22.2 No. 60950-1-07</li> </ul>
EMC	<ul style="list-style-type: none"> <li>• FCC Part 15, Subpart B, Class B</li> <li>• CE</li> </ul>



Subject to design and functionality changes until product shipping.

Distributed by



1-800-236-0112  
www.tapconet.com

5100 West Brown Deer Road  
Brown Deer, WI 53223

